

# Simulation Software for PV Systems



Meteorological Expression			
<b>Required Data</b>			
Horizontal Global Irradiance	hourly	hourly or monthly	monthly
Diffuse Irradiance	hourly	hourly or monthly	monthly
Air Temperature	hourly	hourly or monthly	monthly
<b>Supported Database</b>			
Number of stations	more than 3000	330	2385
Database Type	EnergyPlus	2126 stations	
	TMY3	1020 stations	
	METPV-11	837 stations	
	METPV-3	836 stations	
	Meteonorm	importable	
Geometrical Expression			
Angle Free Operation	Pan / Tilt / Zoom	Pan / Tilt / Zoom	Pan / Tilt / Zoom
PV Module Placement	●	△	●
PV Array Generation / Placement	●	△	●
Automatic PV Array Placement	●	×	×
PV Strings Configuration	●	×	●
3D Model Positioning	Move / Copy / Rotation	●	●
3D Model Data Importing	STL format	Helios 3D format	×
Background Texture Image	GIF / JPEG / BMP / PNG / TIFF format	×	×
Shading Effects	●	△	●
Reflected Light Effects	●	×	×
3D View Still Images Output	GIF / JPEG / BMP / PNG / TIFF format	●	×
3D View Movie Output	AVI format / Animation GIF	×	×
Electrical Expression			
<b>Supported Database</b>			
Grid Connected Systems	●	●	●
Stand-alone Systems	●	●	●
<b>Supported Database</b>			
Supported Devices	Transformer, Cable, Inverter, Combiner Box, Step-up Converter, PV Module(PV Strings), and User defined Load Devices	Inverter, PV Module	Inverter, PV Module
Results Expression			
<b>On Screen</b>			
Summary	●	●	×
Detail Data Tables and Charts	●	●	×
<b>Reports</b>			
Excel-based Reports	●	×	×
Printed Reports	●	●	●
System Requirement			
<b>PC Specs</b>			
OS	Windows XP SP3 (32bits) Windows Vista SP2 (32bits) Windows 7 (32bits, 64bits)		
Microsoft .net Framework	.net Framework 3.5 or higher		
Microsoft Office	Excel® 2003 or higher		
Memory	1.0GB or higher		
Disk	2.5GB		
Graphics	OpenGL 3.0 compatible graphics card		

*Field Logic has been developing and selling simulation and monitoring applications for PV systems in Kyoto, Japan.*



**Measurement Software**

Beans® is a simple and flexible standard software suite for monitoring and analyzing measurement data.



**Light Digital Signage Software**

Festa2® is a Flash®-based digital signage software. Ideal for broadcasting your message coupled with visualized measurement data.



**Monitoring Software**

Owl® enables users to monitor all measurement sites on a single display.

**Contact Field Logic Inc. in Europe**

ConWeb GmbH  
Geschäftsführer/Managing Partner  
Herzog-Albrecht-Weg 10  
85551 Kirchheim b. Munchen  
Germany

Tel.: +49-(0)89-9037044  
Fax.: +49-(0)89-9043650  
Mobile: +49-(0)172-8303886  
wolfgang.geist@conweb.de  
www.f-logic.jp/global

**Contact Field Logic Inc.**

3F Augusta Bldg. 34-9  
Uchihata Kohata  
Uji-city Kyoto, 611-0002  
Japan

Tel.: +81-774-31-4186  
Tel.: +81-774-39-3890  
info@heliobase.com  
www.f-logic.jp/global

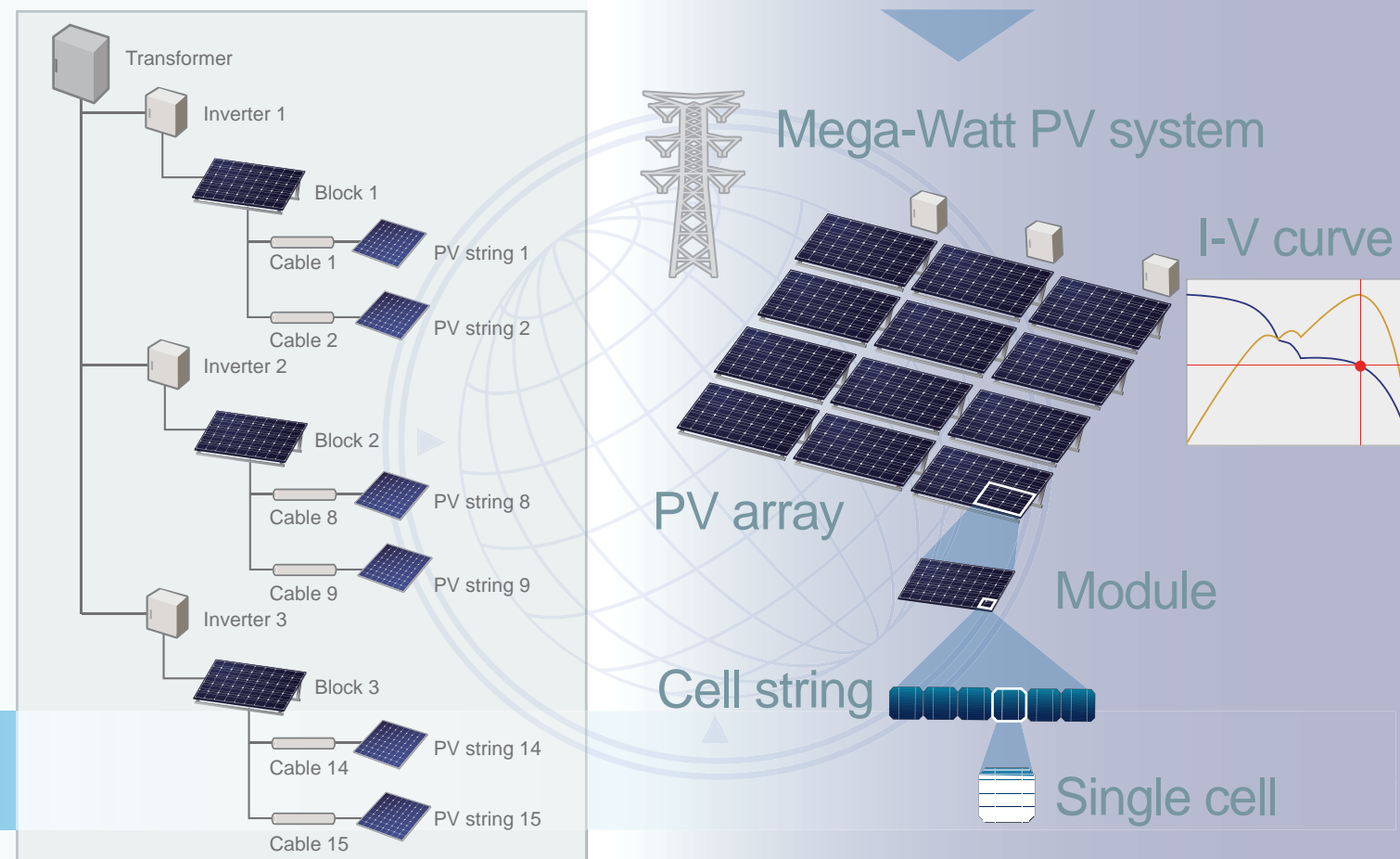

Step1

# Location and Meteorological Data

Step2

# 3D Geometrical Expression

Step3

# Flexible Representation of PV System Structure

# Design Support Features

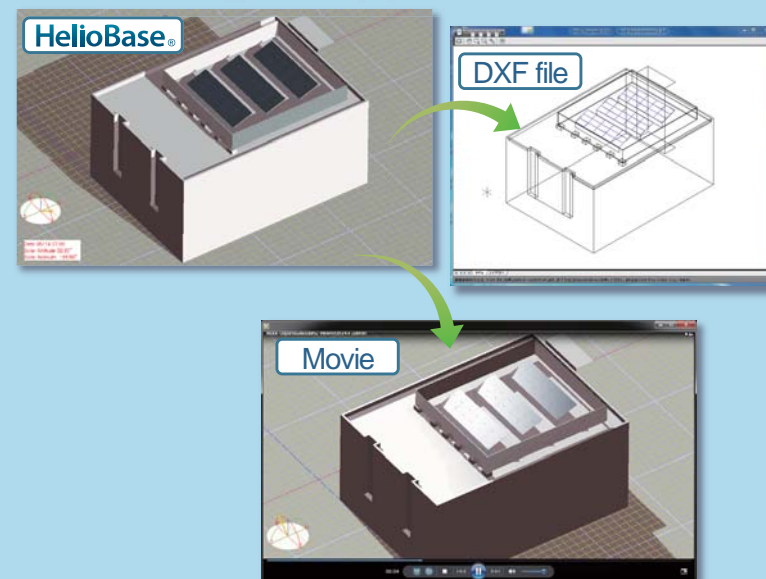
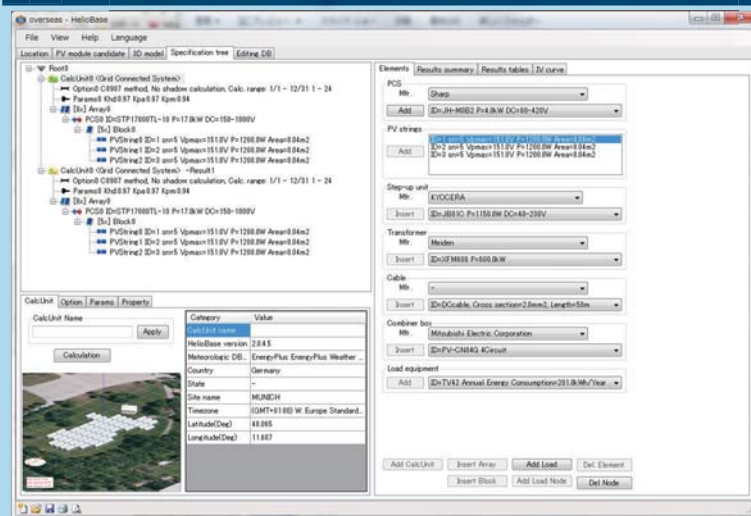
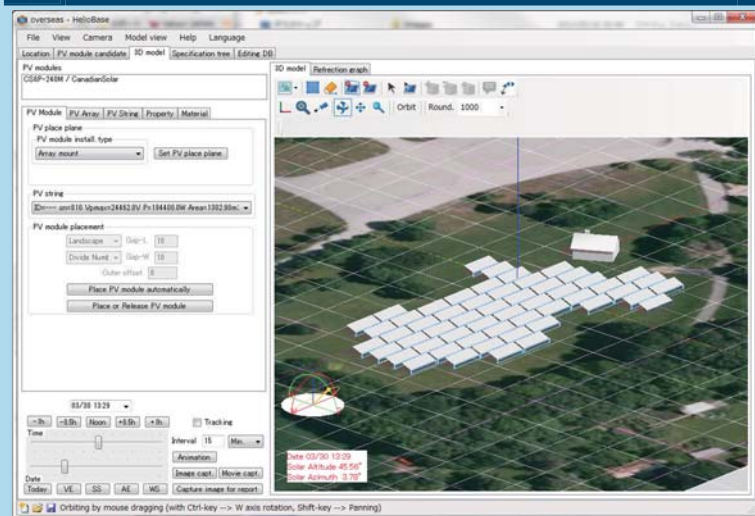
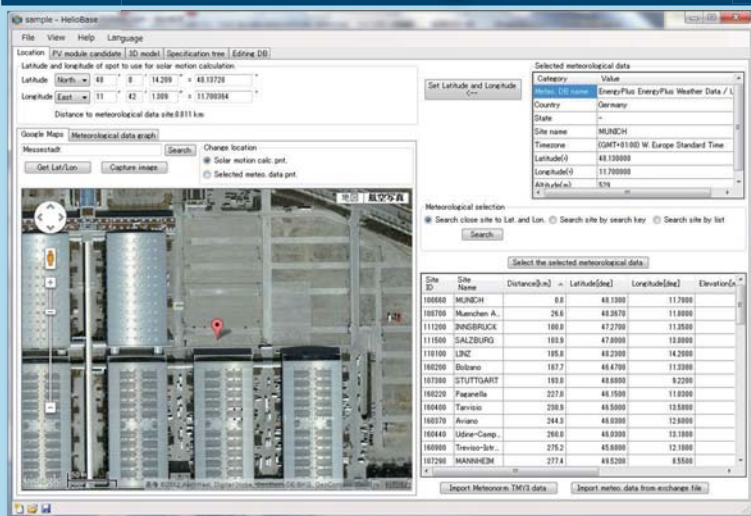

## Precise location of the PV system

Precise location of the target PV system simulates the position of the sun accurately. Because Heliobase® calculates power output on an hourly basis, precise simulation of the sun's position is necessary. With the location setting screen, specific longitude and latitude are easily input with an online world-wide map.

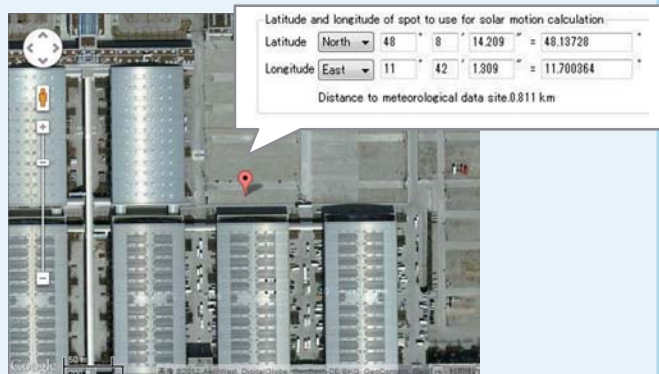

## Hourly meteorological data

Thousands of weather stations are available to give data on meteorological conditions for calculating the system's power production. Heliobase® uses hourly data, usually from the nearest meteorological station, to re-create weather conditions precisely.

### METEOROLOGICAL DATABAS

- Energy Plus 2126 stations
- TMY3 837 stations
- METPV-3/11 1020 stations
- METEONORM (Importable)

## Layout of PV arrays and 3D models

With Heliobase®'s layout function, PV arrays and other 3D models such as buildings can be placed in 3D space. Moving and rotating functions help users to create and adjust the layout and design a sophisticated configuration.

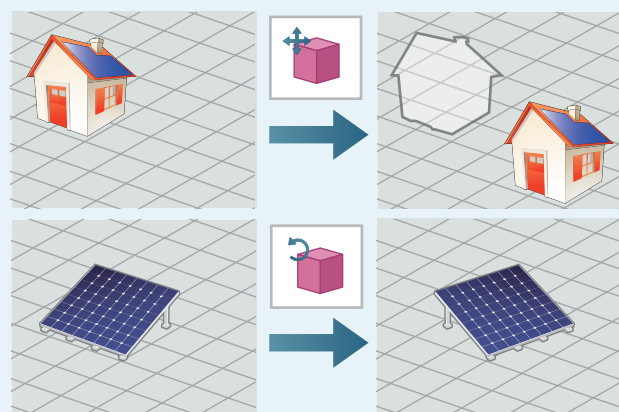

## Importable 3D models

Heliobase® accepts files formatted with STL as valid data for 3D models. STL files are importable simply by dragging and dropping.



### What is an STL file?

STL is a common data format for 3D models. Data from many 3D CAD and modeling software programs such as Google SketchUp can be exported into this format.

## Power calculation with System devices combination

Heliobase® finds the total system output power by calculating the power production and loss of each device. This patented calculation and expression method clarifies in detail the power generation and loss.

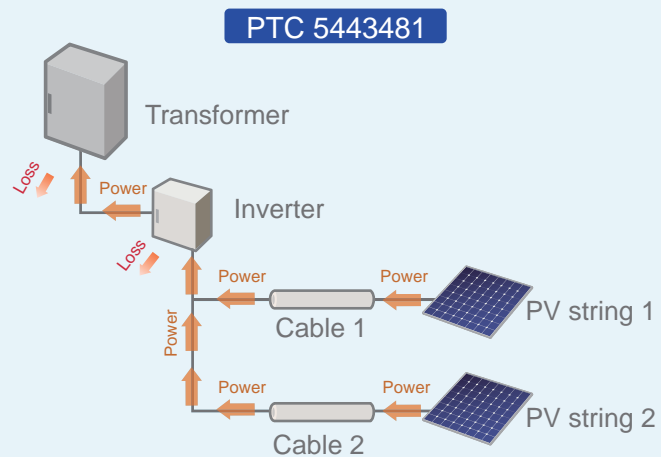

## Cell Level I-V curve calculation

Heliobase® resolves the model level I-V curve at the cell level and takes into account shading effects at the cell string level. Because of this detailed analysis, Heliobase® can take into account PV array mismatches with the I-V curve and offer a true picture of the performance of the PV system.

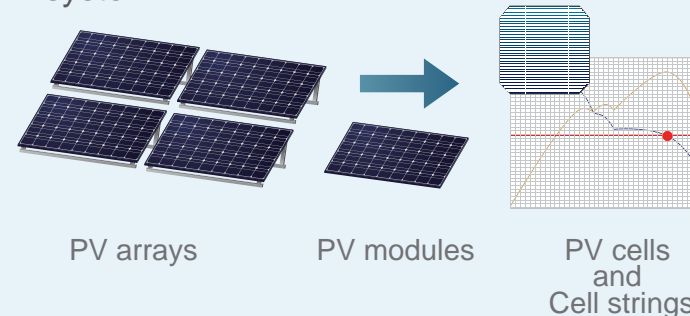

## Exportable Layout Data

Layout created in 3D space can be exported in a DXF file format so that the layout information can be used in other CAD software programs.

## Shading Effects and Reflected Light

Once a layout is created in 3D space, shading and the reflected light of all objects are drawn for each date and time. Daily changes in shading and reflected light can be exported as a movie file or as still images for each time of day for any specific date.

## Reports

Simulation results can be saved in Microsoft Excel® format. Various conditions and data results can be shown in this format.

